



- (51) International Patent Classification:
H01F 37/00 (2006.01)
- (21) International Application Number:
PCT/US2010/028746
- (22) International Filing Date:
25 March 2010 (25.03.2010)
- (25) Filing Language: English
- (26) Publication Language: English
- (30) Priority Data:
61/163,778 26 March 2009 (26.03.2009) US
- (72) Inventors; and
- (71) Applicants : STUDER, Philip, Albert [US/US]; 3126 Gracefield Road, Apt. 209, Silver Spring, MD 20904 (US). SHAPERY, Sandor, Wayne [US/US]; 402 West Broadway, #1200, San Diego, CA 92101 (US).
- (74) Agent: ABUMERI, Mark, M.; Knobbe Martens Olson & Bear, LLP, 2040 Main Street, Fourteenth Floor, Irvine, CA 92614 (US).
- (81) Designated States (unless otherwise indicated, for every kind of national protection available): AE, AG, AL, AM,

AO, AT, AU, AZ, BA, BB, BG, BH, BR, BW, BY, BZ, CA, CH, CL, CN, CO, CR, CU, CZ, DE, DK, DM, DO, DZ, EC, EE, EG, ES, FI, GB, GD, GE, GH, GM, GT, HN, HR, HU, ID, IL, IN, IS, JP, KE, KG, KM, KN, KP, KR, KZ, LA, LC, LK, LR, LS, LT, LU, LY, MA, MD, ME, MG, MK, MN, MW, MX, MY, MZ, NA, NG, NI, NO, NZ, OM, PE, PG, PH, PL, PT, RO, RS, RU, SC, SD, SE, SG, SK, SL, SM, ST, SV, SY, TH, TJ, TM, TN, TR, TT, TZ, UA, UG, US, UZ, VC, VN, ZA, ZM, ZW.

(84) Designated States (unless otherwise indicated, for every kind of regional protection available): ARIPO (BW, GH, GM, KE, LR, LS, MW, MZ, NA, SD, SL, SZ, TZ, UG, ZM, ZW), Eurasian (AM, AZ, BY, KG, KZ, MD, RU, TJ, TM), European (AT, BE, BG, CH, CY, CZ, DE, DK, EE, ES, FI, FR, GB, GR, HR, HU, IE, IS, IT, LT, LU, LV, MC, MK, MT, NL, NO, PL, PT, RO, SE, SI, SK, SM, TR), OAPI (BF, BJ, CF, CG, CI, CM, GA, GN, GQ, GW, ML, MR, NE, SN, TD, TG).

Published:

— without international search report and to be republished upon receipt of that report (Rule 48.2(g))

(54) Title: METHOD AND SYSTEM FOR TRANSPORTATION USING A MAGNETIC BEARING STRUCTURE

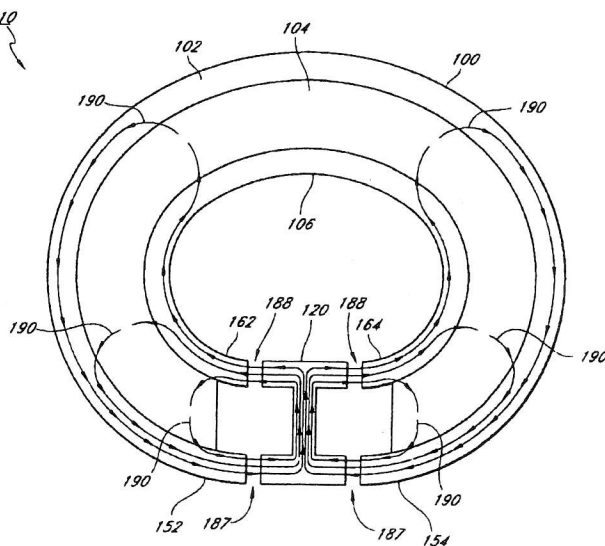

FIG. 1B

(57) Abstract: A method and system for transportation using a magnetic bearing structure is disclosed. In one aspect, an apparatus for carrying a load comprises a source of magnetic flux and a controller configured to control the position of the source of magnetic flux relative to a magnetizable structure. The source of magnetic flux comprises a first upper portion and a first lower portion of opposite polarities. The first portions are spaced apart horizontally from a first side of the magnetizable structure. The source of magnetic flux further comprises a second upper portion and a second lower portion of opposite polarities. The second portions are spaced apart horizontally from a second side of the magnetizable structure. The second side is opposite the first side. The first and second upper portions are magnetically attracted to an upper portion of the magnetizable structure and the first and second lower portions are magnetically attracted to a lower portion of the magnetizable structure.